



88085.530



3D-Effekt



1 4 x 2802	2 4 x 2801	gedämpft 3 3 x 1506	ungedämpft 4 3 x 1507	5 6 x 1614
6 3,5 x 15 26 x 2804	7 8 x 30 16 x 2861	8 4 x 30 4 x 2812	9 5,8 x 55 2 x 2840	10 8 x 30 2 x 2842
11 2 x 2843	12 6 x 2865	13 Leim 1 x 2863	14 24 x 2819	15 3 x 15 6 x 2803
16 25 x 2862	17 1 x 2 x	19 1 x 1 x 4 x	20 3 x	



Das beigefügte Wandbefestigungsmaterial (Dübel und Schrauben) eignet sich nur für festes Mauerwerk (z.B.: Beton- oder Ziegelwände). Für andere Wandaufbauten sind eventuell Spezialdübel und andere Schrauben notwendig. Ziehen Sie gegebenenfalls eine Fachkraft zu Rate.

Приложенный материал для крепления к стене (дюбели и винты) пригоден только для жестких кладок (например, бетонные или кирпичные стены). Для других настенных конструкций необходимы смотря по обстоятельствам специальные дюбели и другие винты. При необходимости проконсультируйтесь у специалиста.

Załączony materiał do mocowania do ściany (kolki rozprężne i wkręty) nadaje się tylko do ścian murowanych (np. z betonu lub cegieł). Do ścian wykonanych w innych technologiach konieczne być mogą specjalne kolki rozprężne i inne wkręty. W razie potrzeby skorzystaj z fachowej pomocy

The accompanying wall mounting hardware (anchors and screws) is suitable only for solid masonry (eg concrete or brick walls). For other wall structures are possibly special anchor bolts and other necessary. Tighten if necessary, an expert.

De begeleidende wandmontage hardware (pluggen en schroeven) is alleen geschikt voor massief metselwerk (bijvoorbeeld beton of bakstenen muren). Voor andere muur structuren zijn eventueel bijzondere ankerbouten en andere noodzakelijke. Draai indien nodig, een deskundige.

Le mur d'accompagnement matériel de montage (chevilles et les vis) ne convient que pour la maçonnerie solide (par exemple en béton ou des murs de briques). Pour les structures de mur d'autres sont peut-être spéciale boulons d'ancrage et d'autres nécessaires. Serrer le cas échéant, un expert.

Il muro di accompagnamento hardware di montaggio (tasselli e viti) è'e adatto solo per muratura piena (ad esempio calcestruzzo o muratura). Per le altre strutture murarie sono forse speciali bulloni di ancoraggio e necessari di altri. Serrare se necessario, un esperto.

Ekteki duvara sabit montaj malzemeleri (dübel ve vidalar), sadece sağlam duvarlar için (örnek: beton veya tuğla) elverişlidir. Başka duvarlar için özel dübeller ve farklı vidalar gerekebilir. Gerektiğinde bir uzmana danışınız.

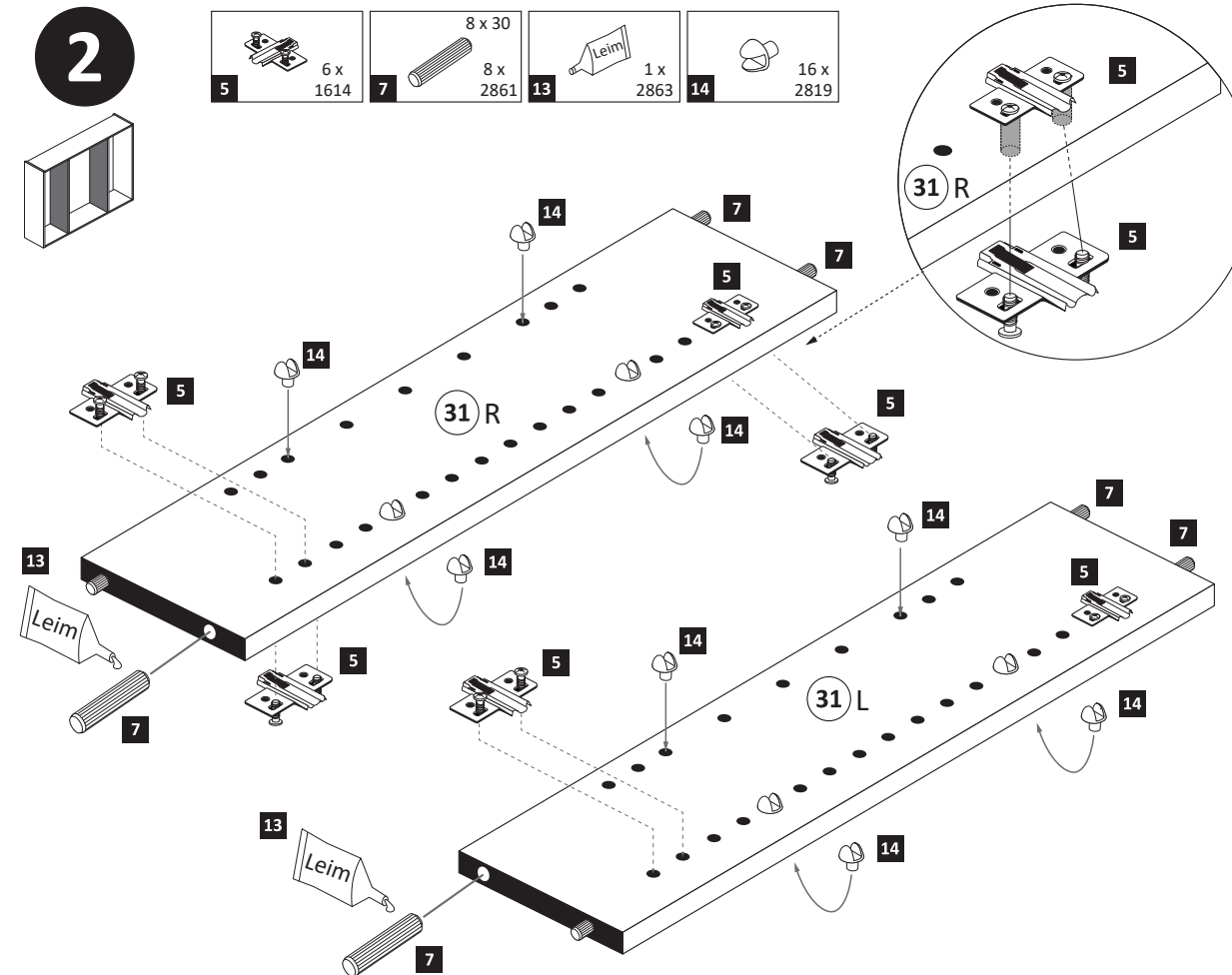
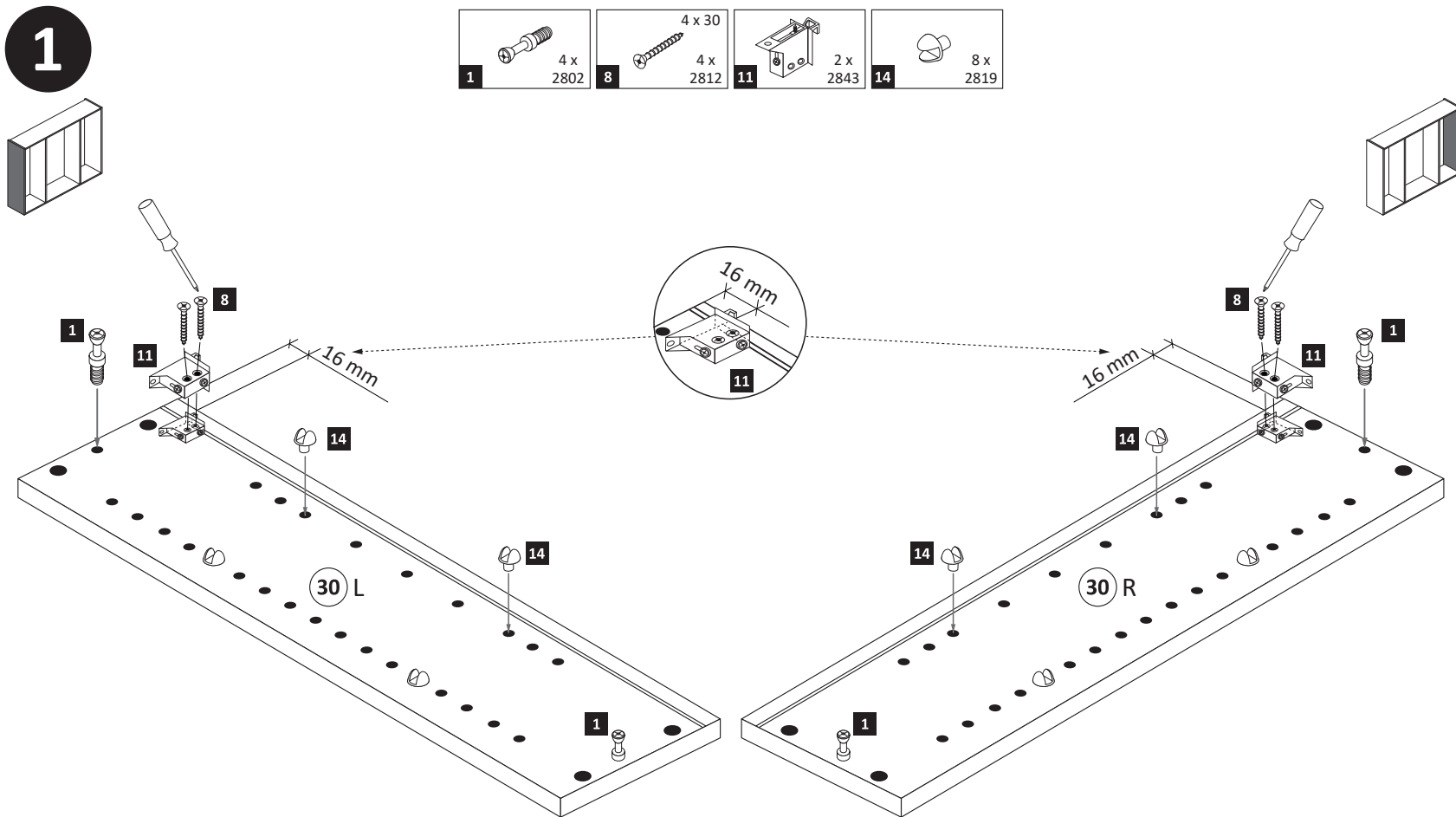
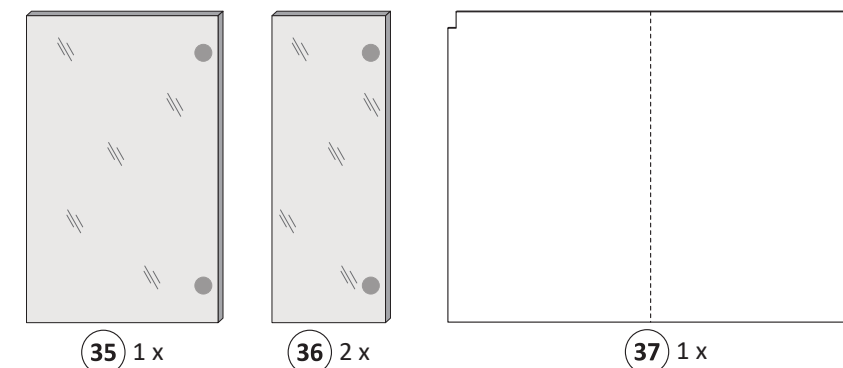
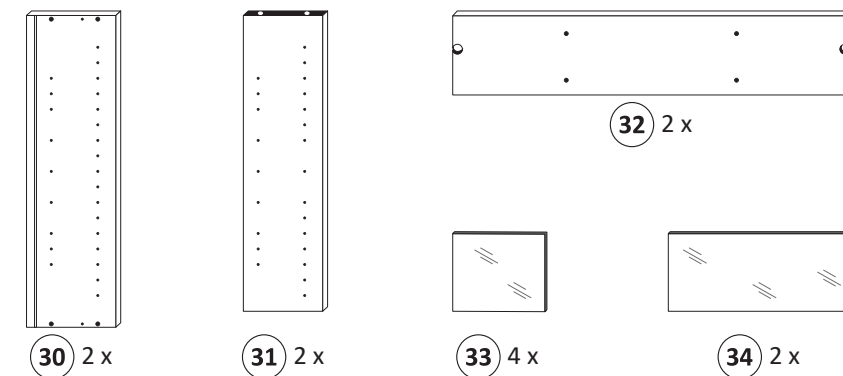

3

- 2 4 x 2801
- 7 8 x 30 2861
- 13 Leim 1 x 2863

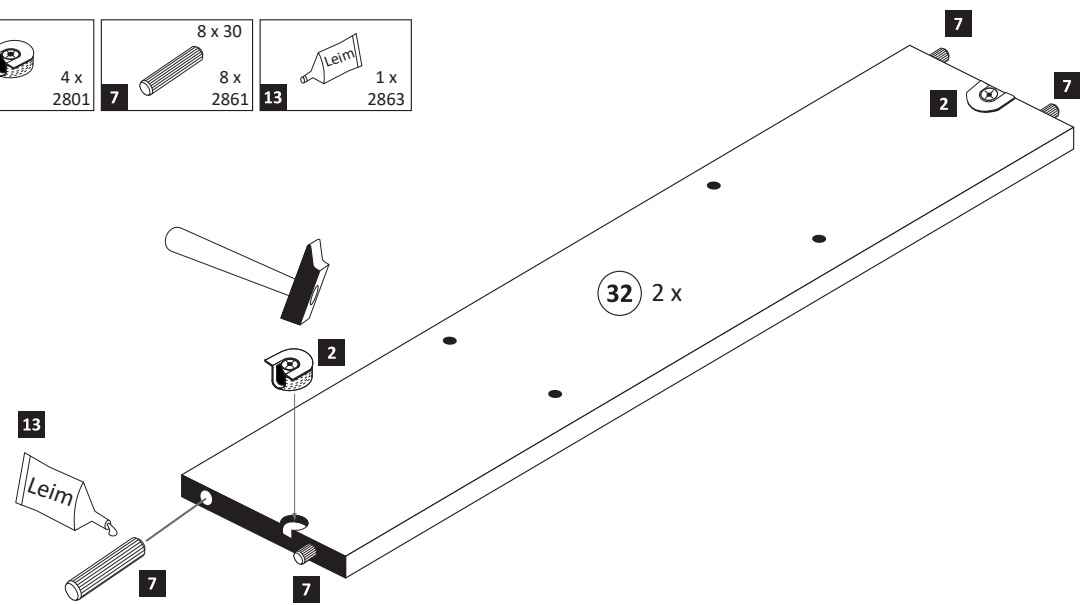

4

- 6 3,5 x 15 2804

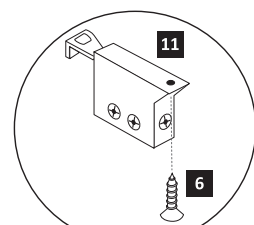
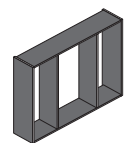

- 13 Leim 1 x 2863
- 20 min.
- D Leim
 - GB Glue
 - NL Lijm
 - PL Klej
 - TR Tutkal
 - F Colle
 - I Colla

Ansicht von links

Ansicht von rechts

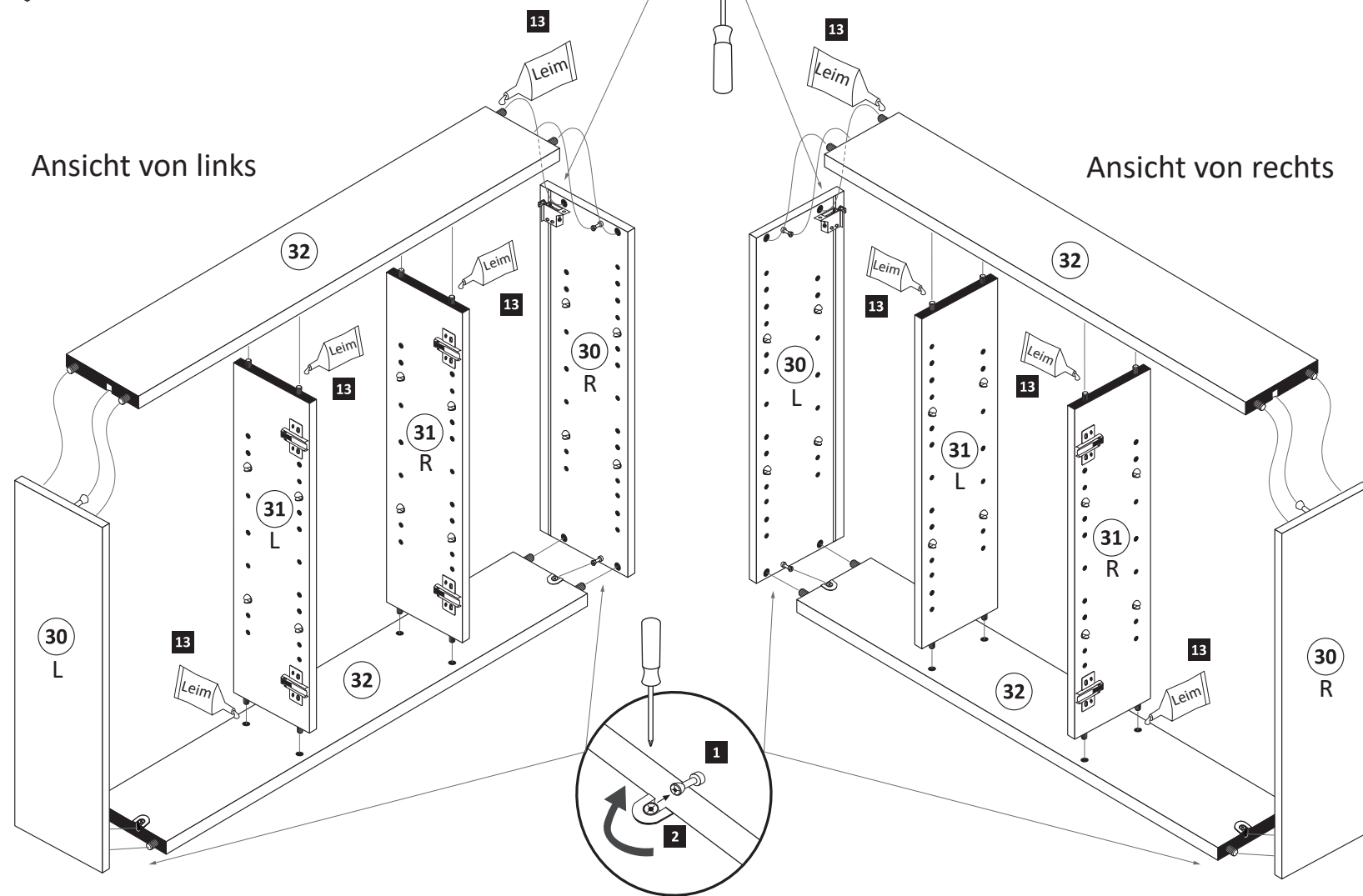

5

Bitte nur eine Variante auswählen und den entsprechenden Ausschnitt in einer Größe von maximal Trafobreite wie Trafohöhe - 10 mm aussägen. Trafomontage wird im Schritt 7 durchgeführt.

Variante 1: Trafomontage unten

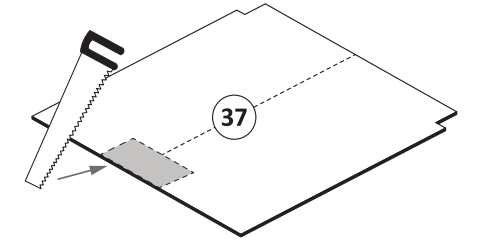
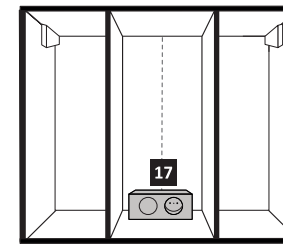

Variante 2: Trafomontage oben

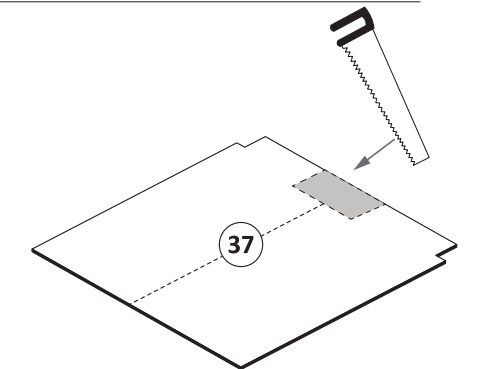
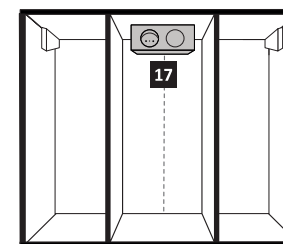

6

- 16 25 x 2862

ACHTUNG !
Folgende Montageschritte mit dem Beispiel „Trafomontage Variante unten“ !

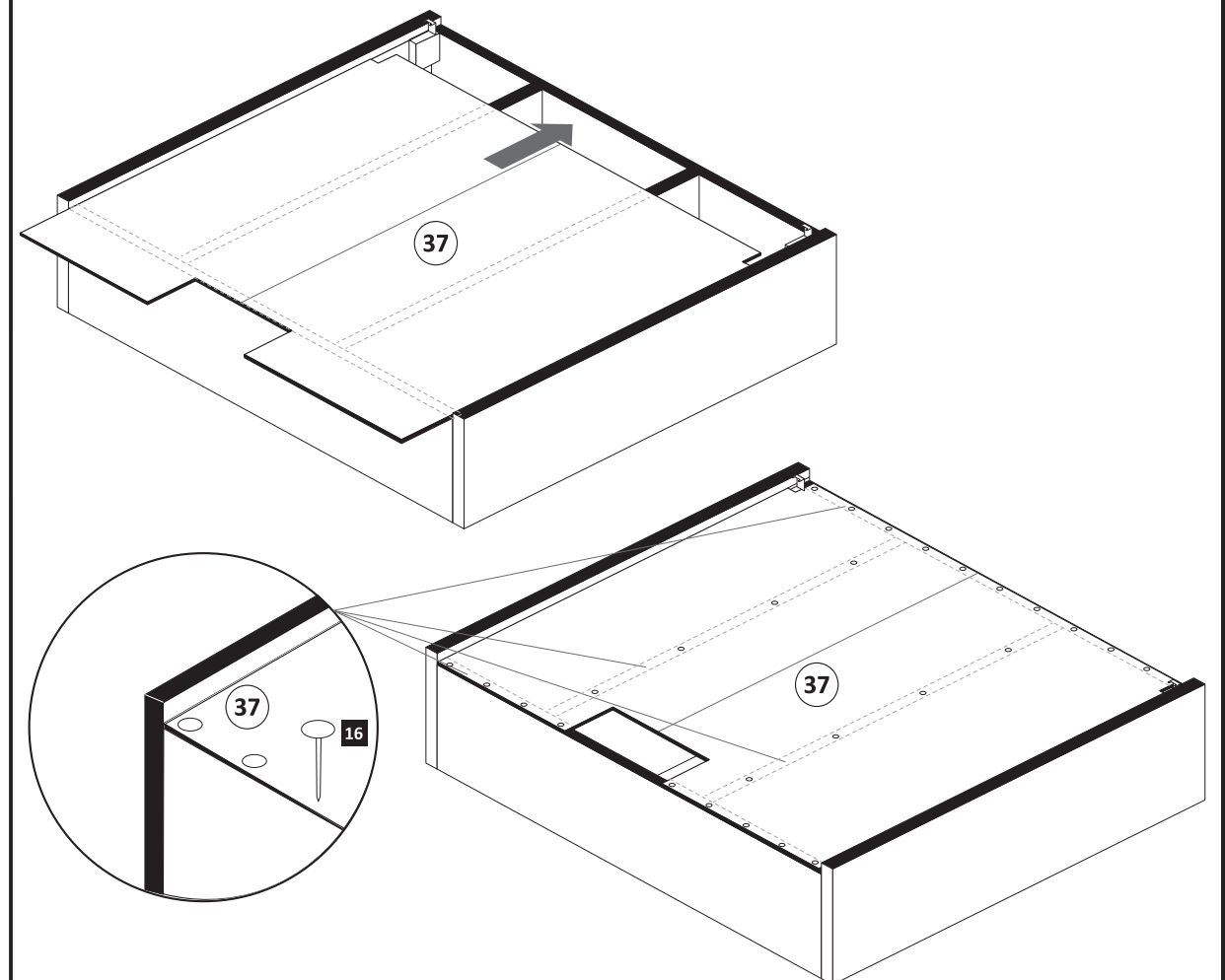

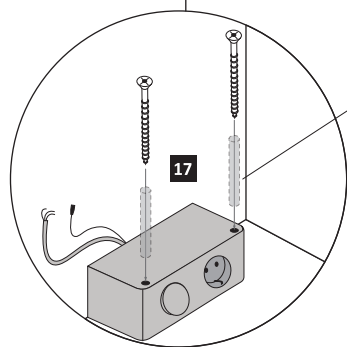
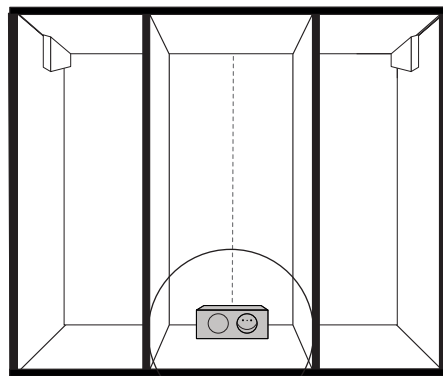
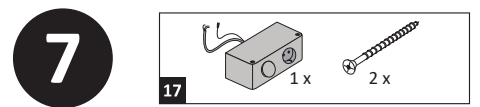

Achtung !!
Die Distanzhülsen
sind optional im
Lieferumfang.
Nur bei Bedarf nutzen.

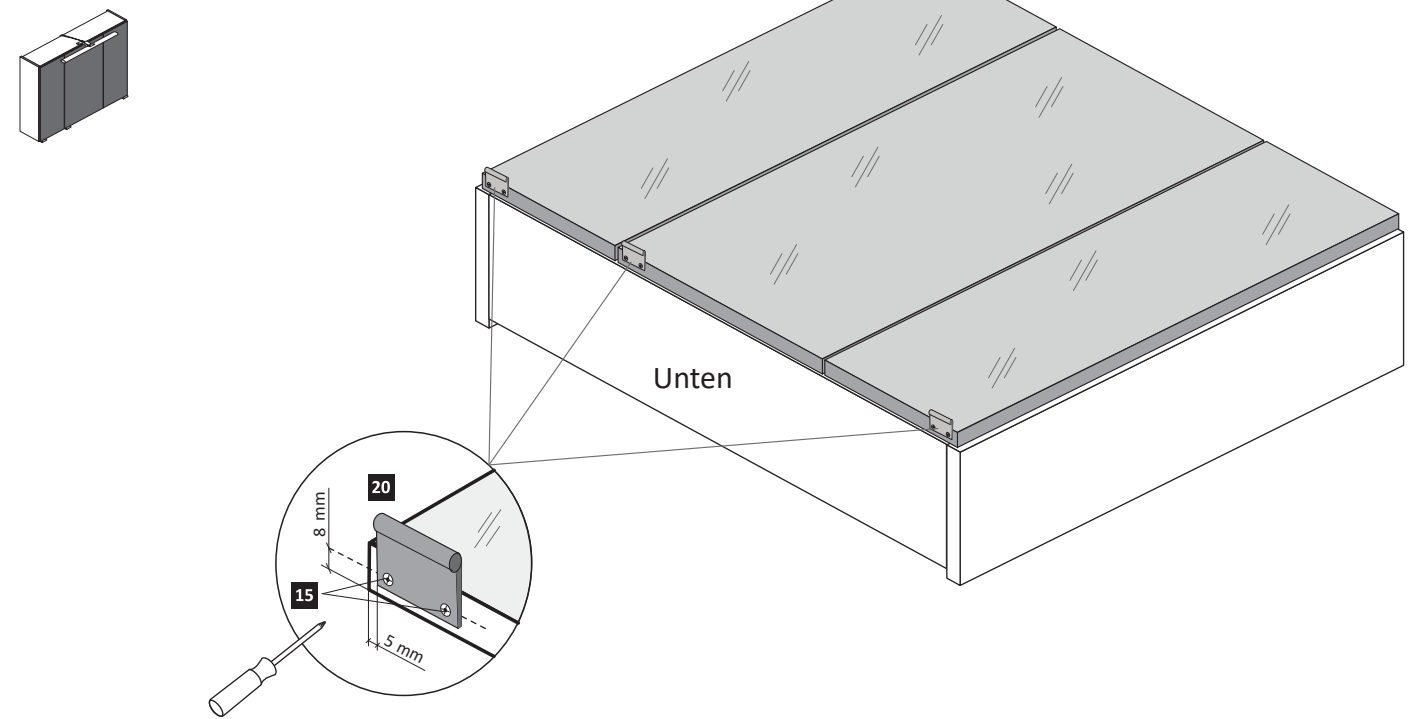
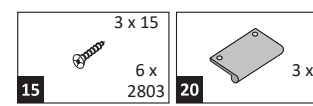
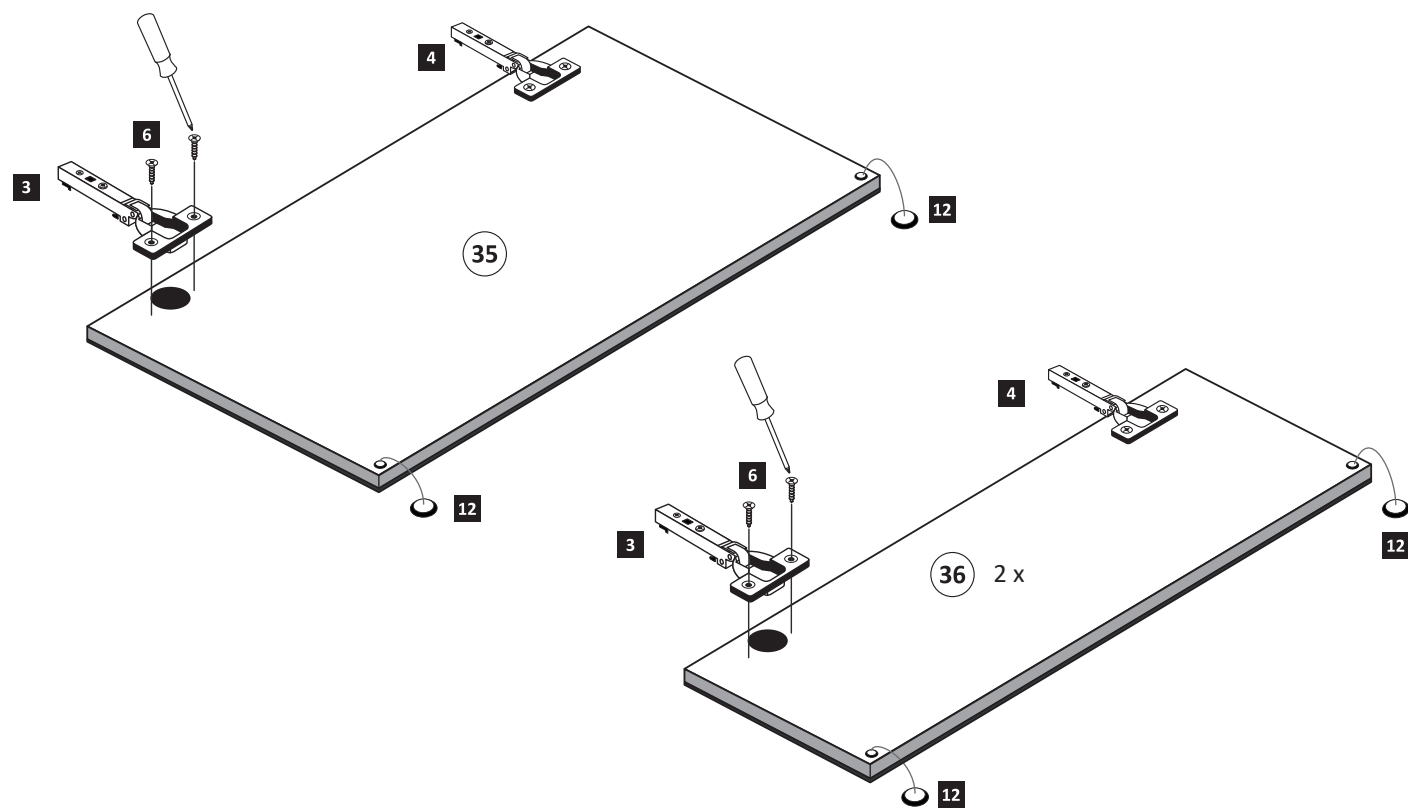
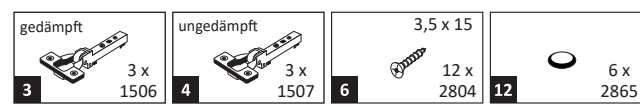
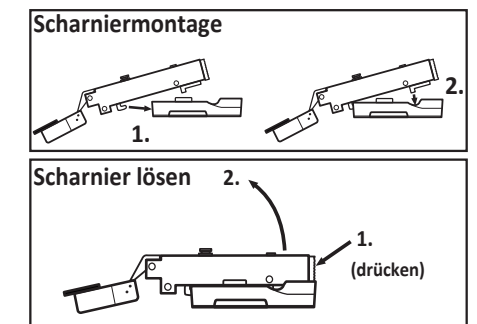
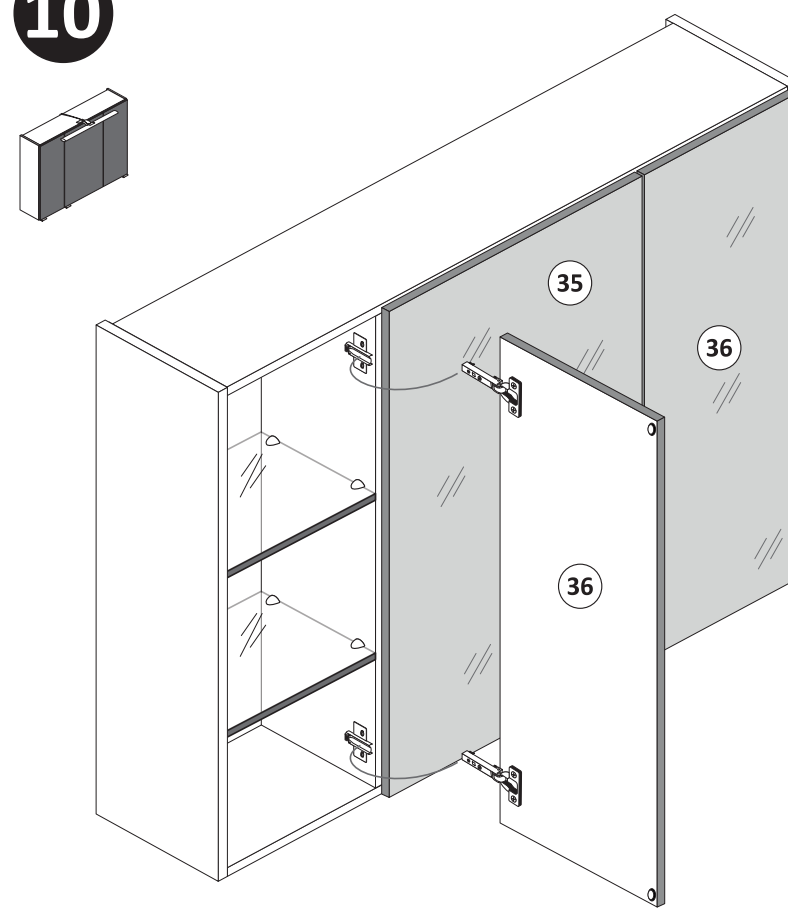
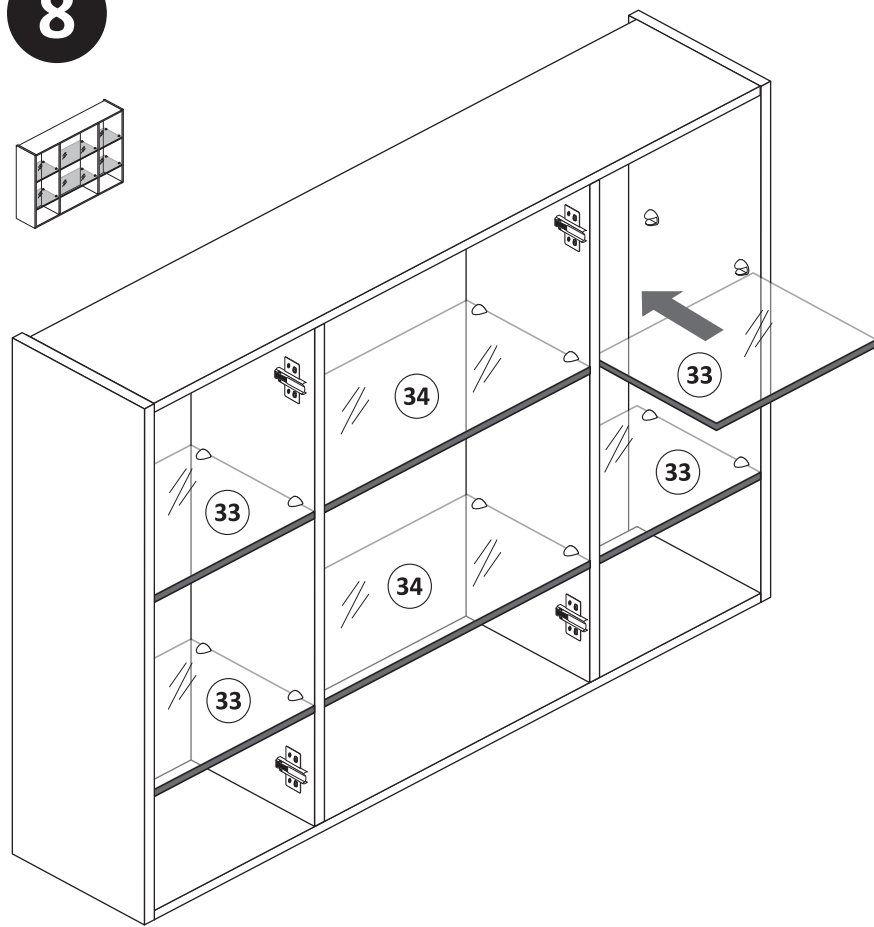

12

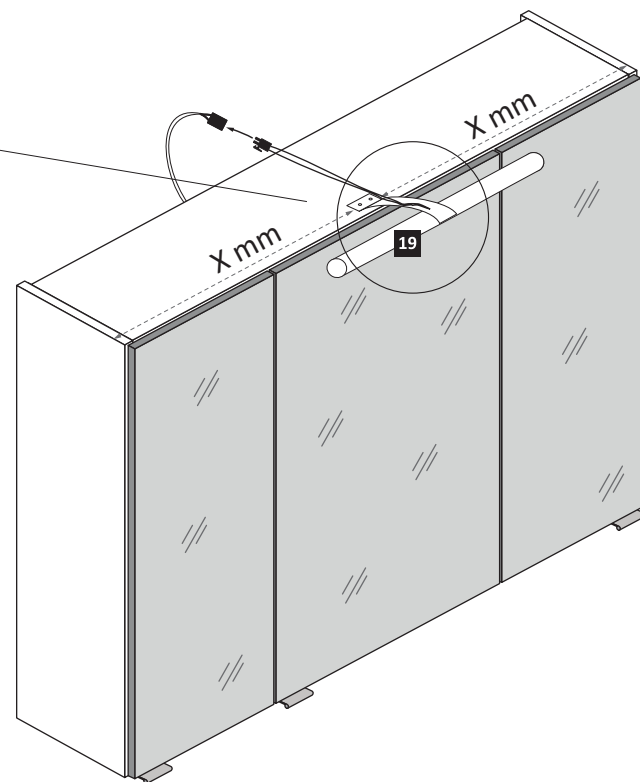
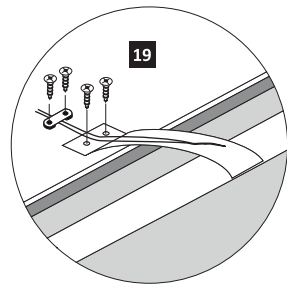
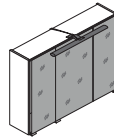
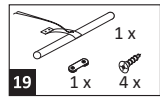

13

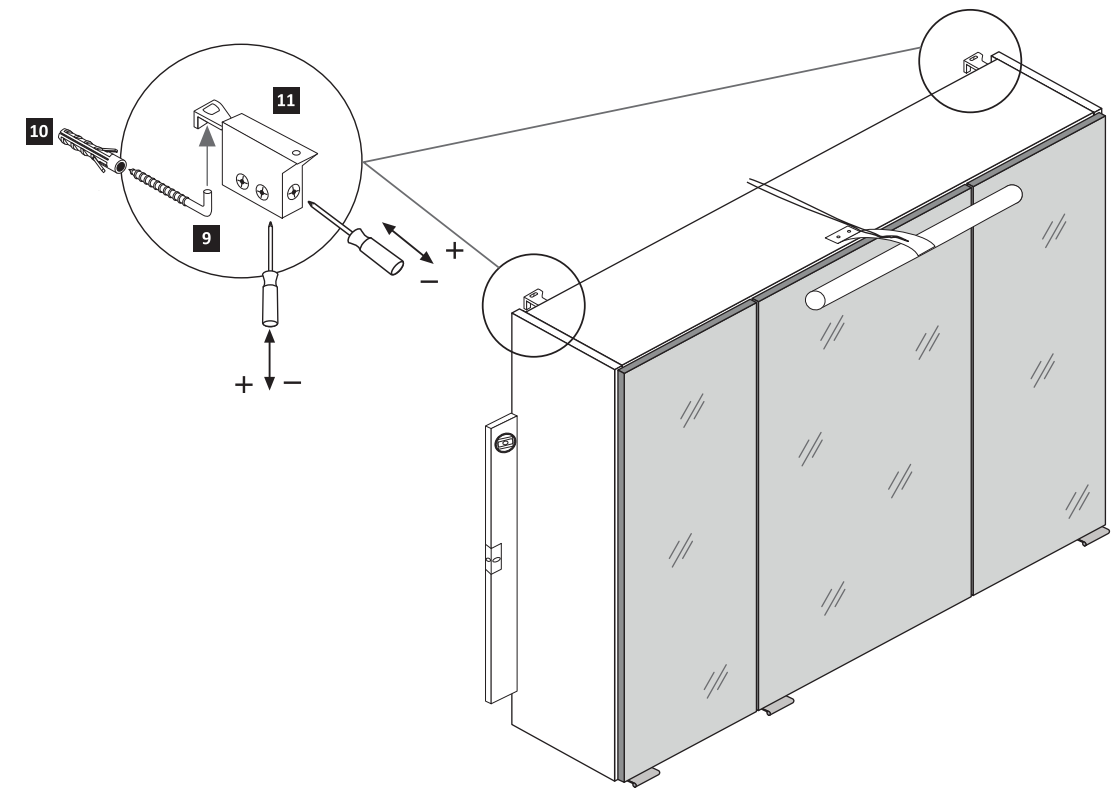
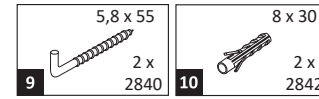

14

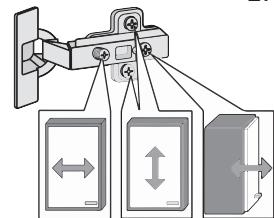
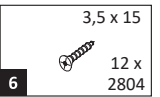

1. Türen einstellen.

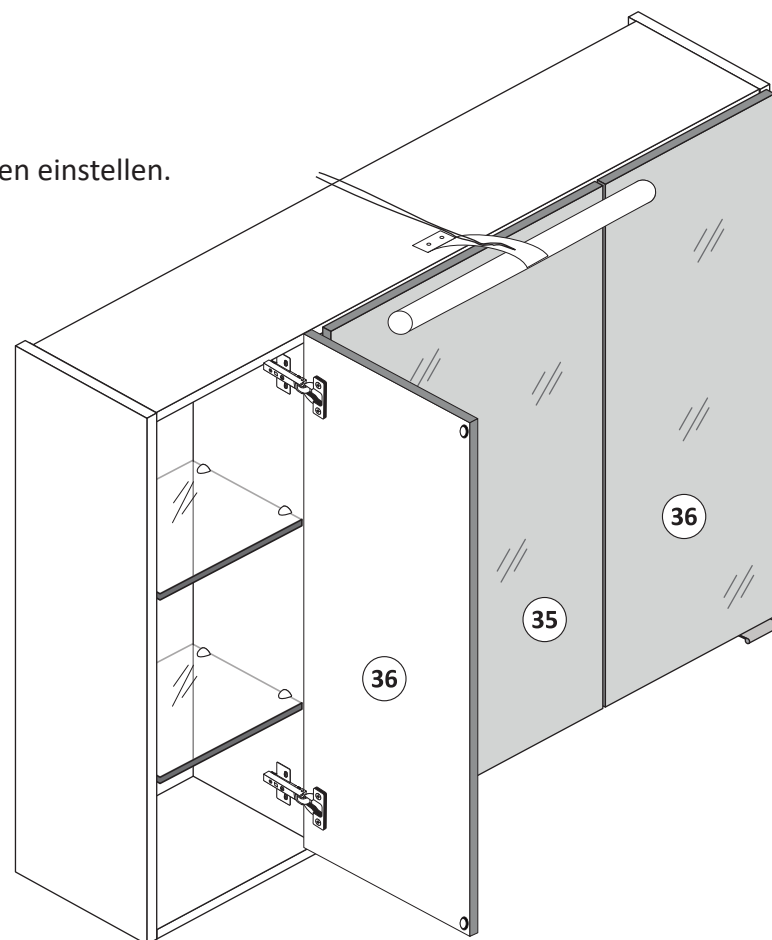

Achtung !!
Aus Sicherheitsgründen ist die Montage der Sicherungsschrauben zwingend notwendig. Nachdem montieren der Sicherungsschrauben ist die Höheneinstellung der Türen nicht mehr möglich!



2. Sicherungsschrauben montieren.

