

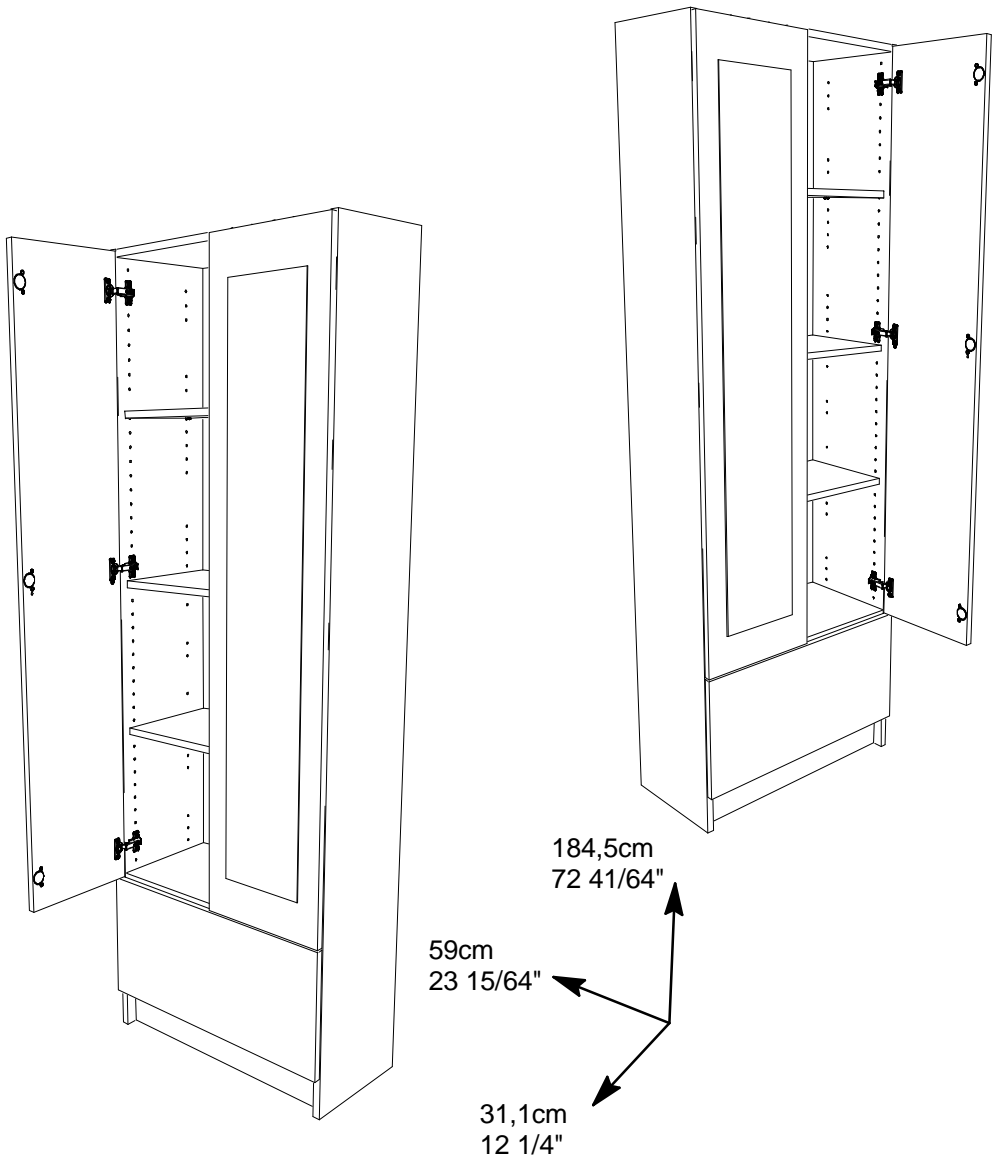

## COLONNE DE SALLE DE BAINS



### FR Remerciements :

Nous vous remercions d'avoir choisi un meuble créé et fabriqué par Ekipa et espérons qu'il vous donnera entière satisfaction.

### EN Thanks :

Thank you for choosing furniture designed and manufactured by Ekipa. We hope you are totally satisfied your purchase.

### DE Danksagung:

Wir danken Ihnen für den Kauf eines Frankreich von der Ekipa entworfenen und hergestellten Möbelstücks und hoffen, dass Sie es zu Ihrer vollkommenen Zufriedenheit finden werden.

### ES Agradecimientos :

Les damos las gracias por haber elegido un mueble diseñado y fabricado por el Ekipa y esperamos que sea de su total agrado.

### PT Agradecimentos :

Obrigado por ter escolhido um móvel concebido e fabricado pelo Ekipa, esperando que seja do seu inteiro agrado.

### IT Ringraziamenti:

Grazie per avere scelto un mobile progettato e fabbricato dal Ekipa. Speriamo soddisfatti appieno le vostre esigenze.

### NL Bedankje:

Wij bedanken u voor de aankoop van een door de Ekipa ontworpen en vervaardigd meubel en hopen dat u er veel plezier aan zult beleven.

### CZ Poděkování:

Děkujeme, že jste si vybrali nábytek navržený a vyrobený společností Ekipa. Doufáme, že budete svým nákupem naprosto spokojeni.

### HU Köszönet:

Köszönjük, hogy a Ekipa által létrehozott és gyártott bútort választott, reméljük, hogy elégedett lesz a termékkel.

### PL Podziękowania:

Dziękujemy za wybór mebli stworzonych i wyprodukowanych przez Ekipa. Mamy nadzieję, że będziecie Państwo w pełni zadowoleni z zakupu.

### RO Mulțumiri:

Vă mulțumim că ați ales un articol de mobilier conceput și fabricat de Ekipa și sperăm că veți fi pe deplin satisfăcuți de acesta.

### RU Благодарность:

Мы благодарим вас за то, что вы выбрали мебель, созданную и произведенную Групп Паризо, и надеемся, что вы будете полностью удовлетворены нашей продукцией.

### SK Pod'akovanie:

Ďakujeme, že ste si vybrali nábytok navrhnutý a vyrobený spoločnosťou Ekipa. Dúfame, že budete svojím nákupom absolútne spokojní.

### TR Teşekkür ederiz:

Ekipa tarafından tasartanan ve üretilen bu mobilyayı seçtiğiniz için teşekkür ederiz. Ürünümüzden memnun kalmanızı ümit ederiz

### AR شكر:

نشكركم لاختياركم هذه القطعة من التصميم وتصنيع مجموعة باريزو Ekipa ونتمنى أن تتل رضاهم.

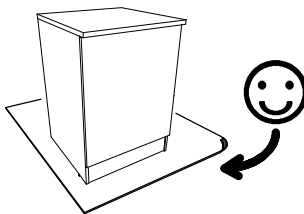
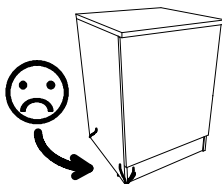
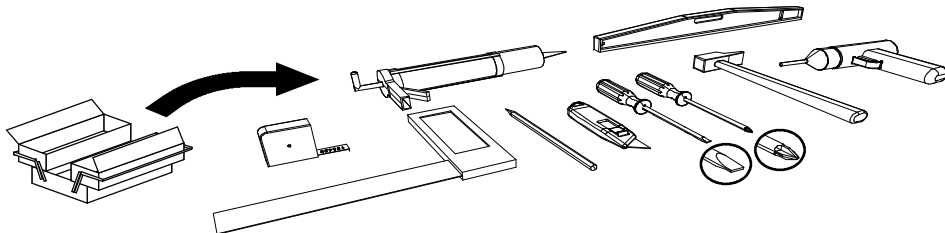



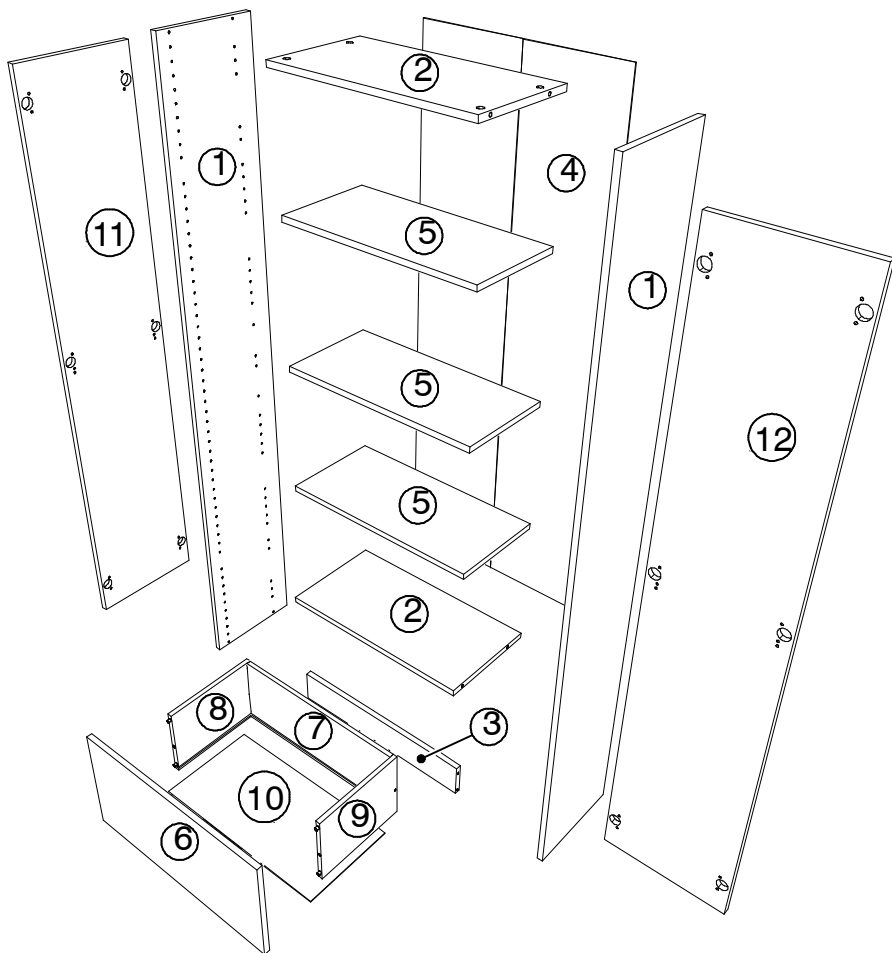



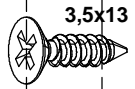
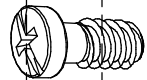
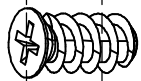
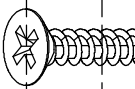

[contact@parisot.com](mailto:contact@parisot.com)

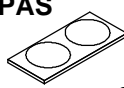
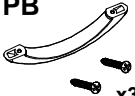
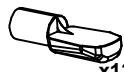

Rep	Qté	mm			inch		
01	2	1841	288,5	16	72 31/64	11 23/64	5/8
02	2	558	288	16	21 61/64	11 21/64	5/8
03	1	558	95	16	21 61/64	3 47/64	5/8
04	1	1500	586	2,5	59 1/16	23 5/64	3/32
05	3	557	267	16	21 59/64	10 1/2	5/8
06	1	587	296	16	23 7/64	11 21/32	5/8
08	1	270	196	12,5	10 5/8	7 23/32	31/64
07	1	508	196	12,5	20	7 23/32	31/64
09	1	270	196	12,5	10 5/8	7 23/32	31/64
10	1	520	269	2,5	20 15/32	10 37/64	3/32
11	1	1442	292	20	56 49/64	11 1/2	25/32
12	1	1442	292	16	56 49/64	11 1/2	5/8

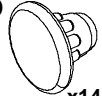
0 1 cm 2 3

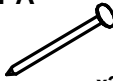
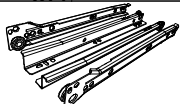
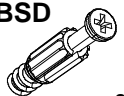
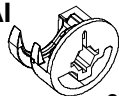
<b>VG</b>		3,5x13	x8
<b>CDS</b>			x24
<b>BWF</b>			x4
<b>WF</b>			x6
<b>ADU</b>			x6

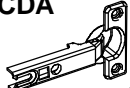
<b>PAS</b>		x3	<b>PB</b>		x3	<b>BWD</b>		x12
<b>BQS</b>		x4	<b>CF</b>		x1	<b>OO</b>		x14
			<b>JE</b>		x6			
<b>ZK</b>		x1	<b>PA</b>		x30	<b>BR</b>		x1
<b>BSD</b>		x8	<b>AI</b>		x8	<b>CDD</b>		x6
			<b>CDA</b>		x6			

**1**

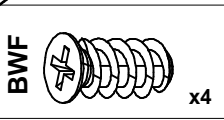
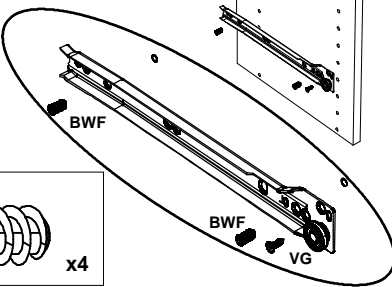
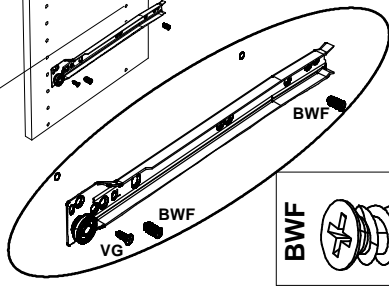
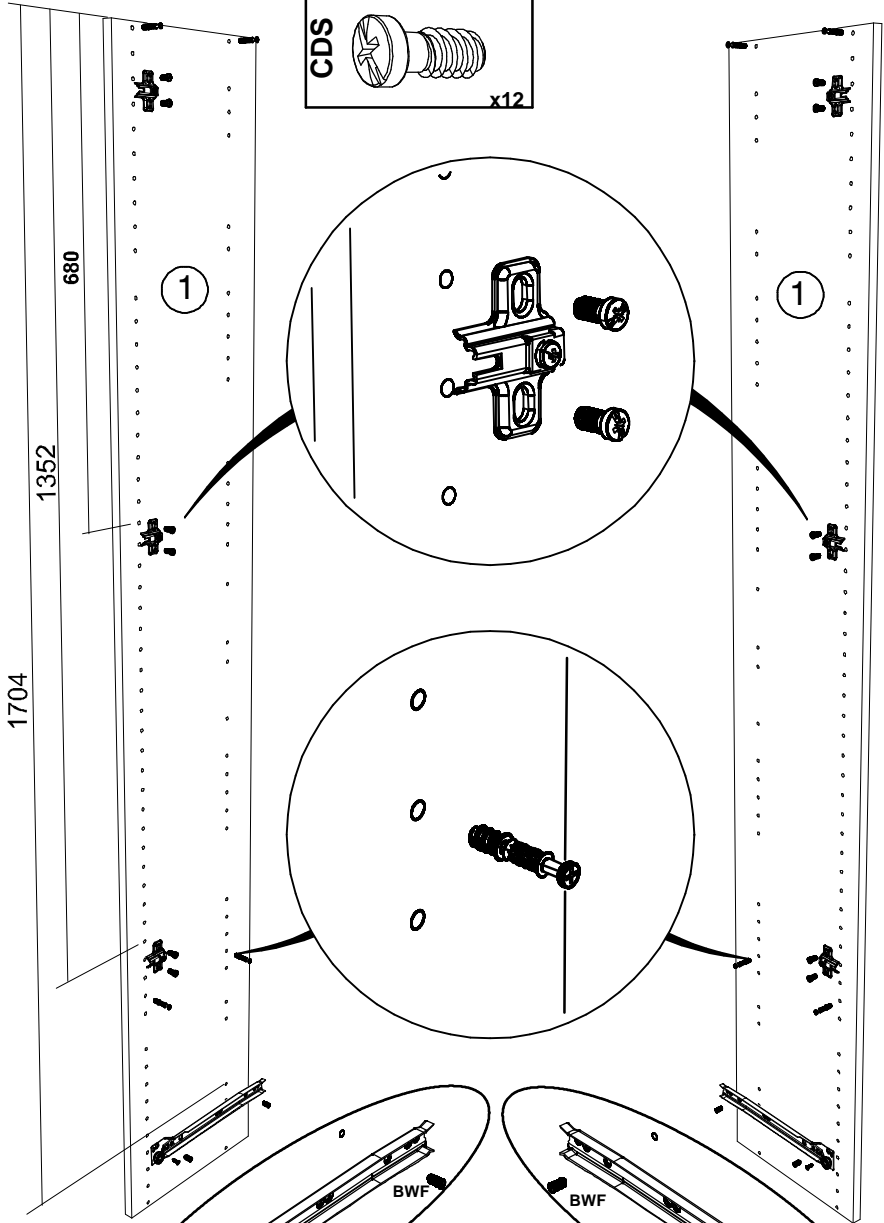
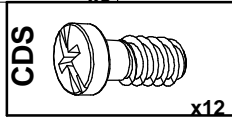
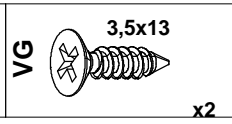
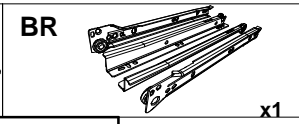
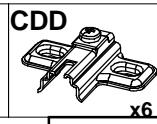
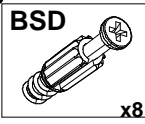

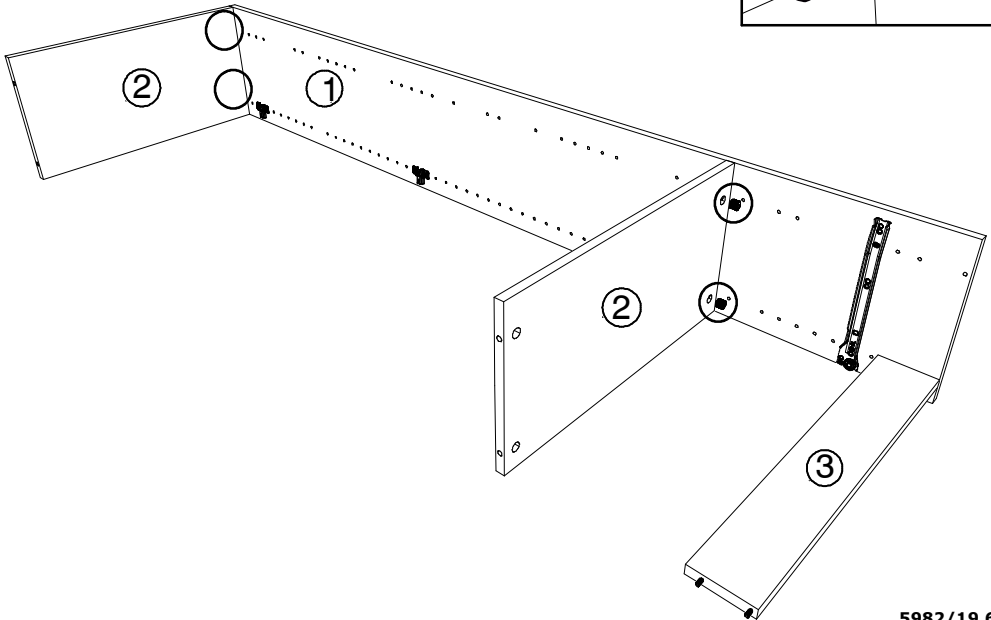
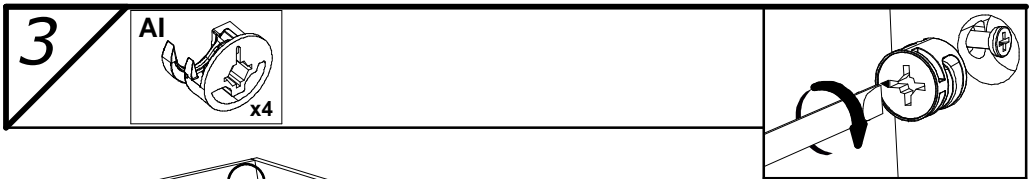
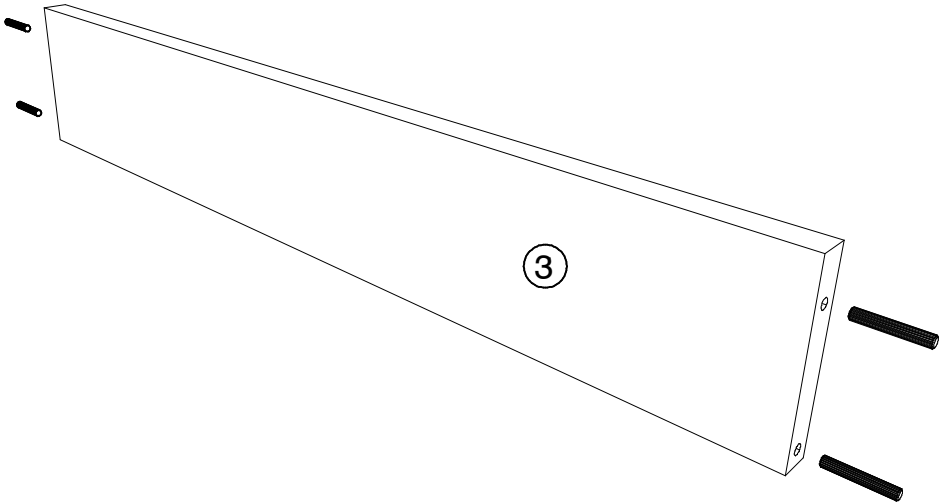
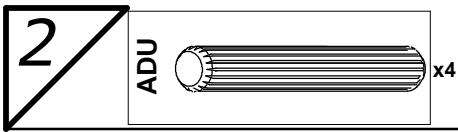

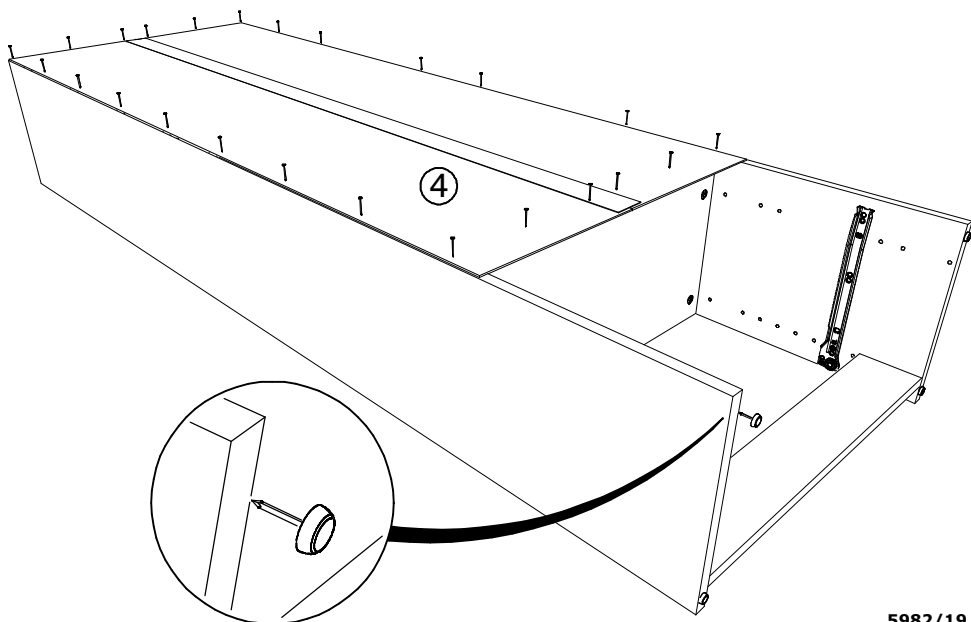
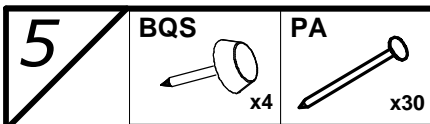
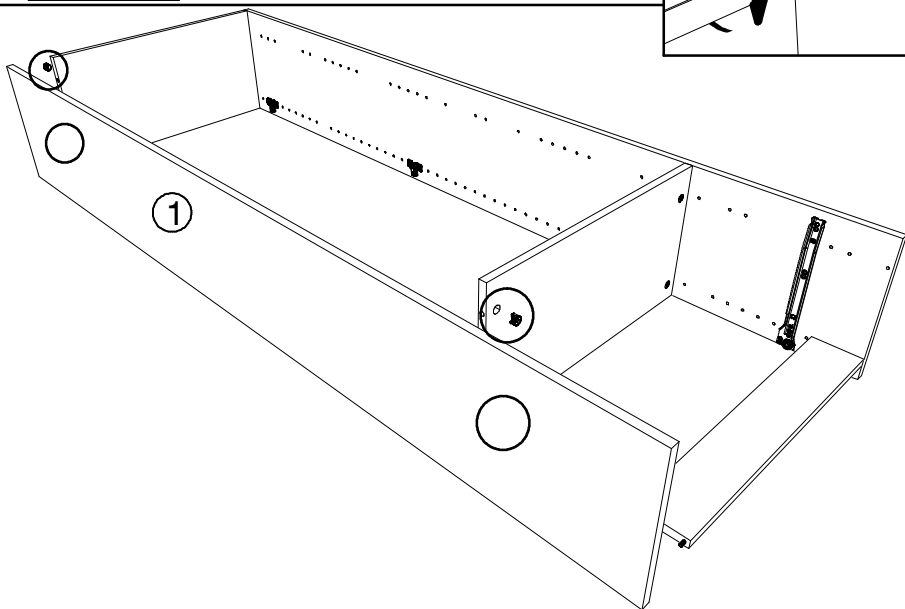
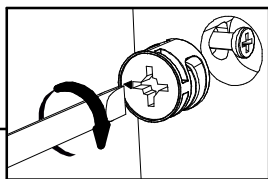
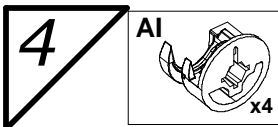

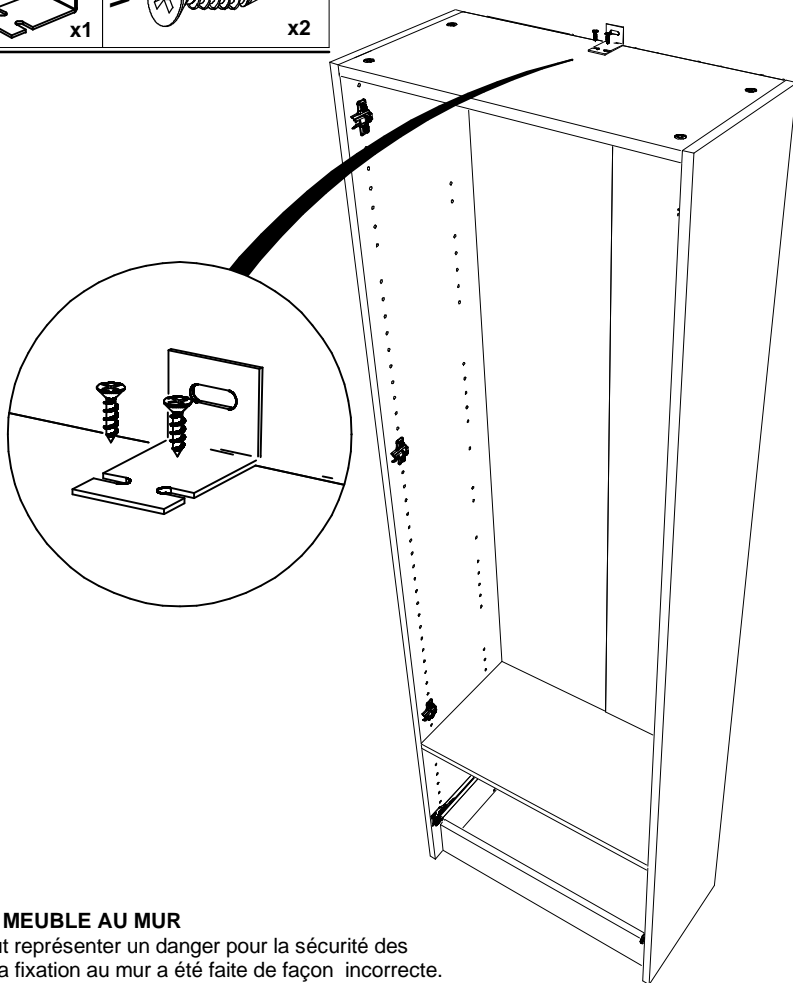
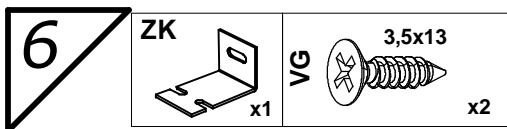

### FIXATION DU MEUBLE AU MUR

Ce meuble peut représenter un danger pour la sécurité des personnes si sa fixation au mur a été faite de façon incorrecte. Cette fixation doit être réalisée par une personne compétente qui s'assurera de l'adéquation entre le dispositif de fixation et le mur.



**UTILISEZ DES VIS ET DES CHEVILLES  
ADAPTÉES A VOS MURS**



Il existe une grande diversité de types de murs ou cloisons, c'est la raison pour laquelle nous ne pouvons vous fournir une quincaillerie adaptée à votre mur. Il est nécessaire d'identifier le type de paroi à laquelle vous allez fixer ce produit afin de vous procurer les fixations appropriées. En cas de besoin, adressez vous à un magasin spécialisé pour conseil.



**FIXATION MURALE OBLIGATOIRE**





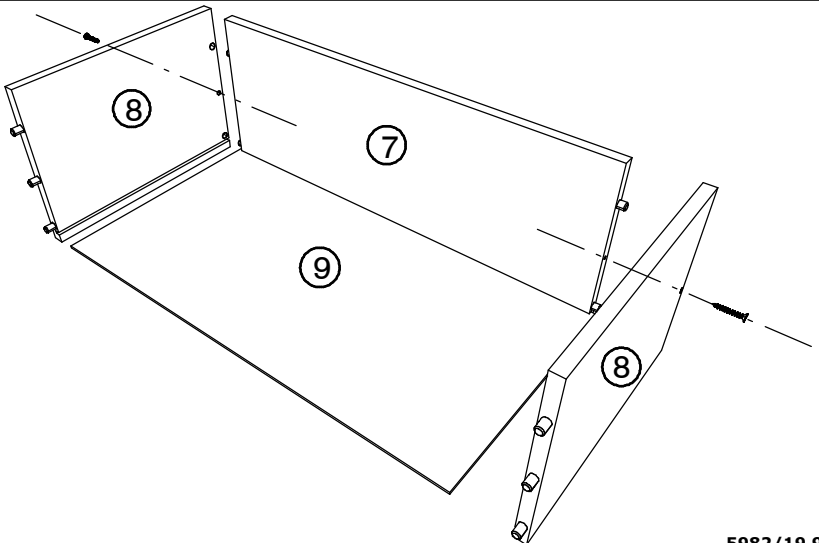
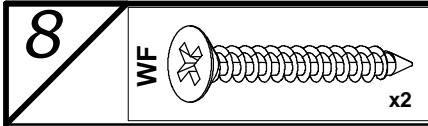
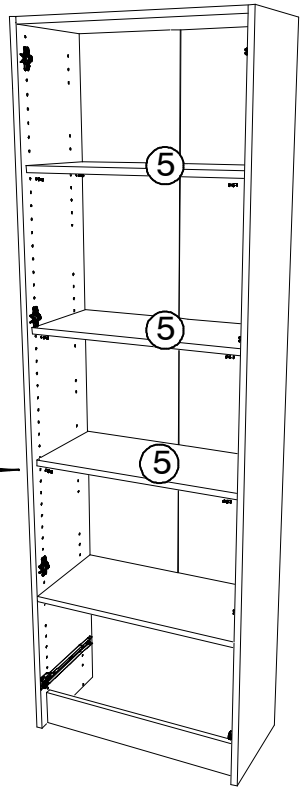
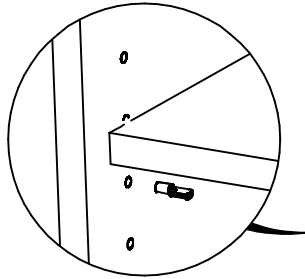
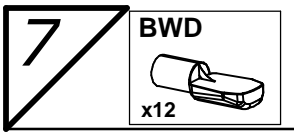

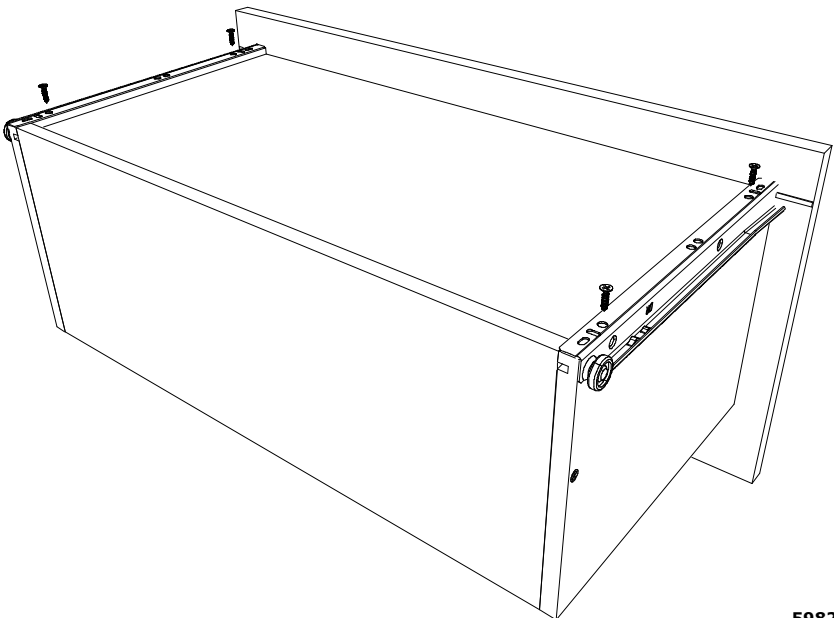
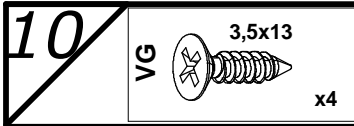
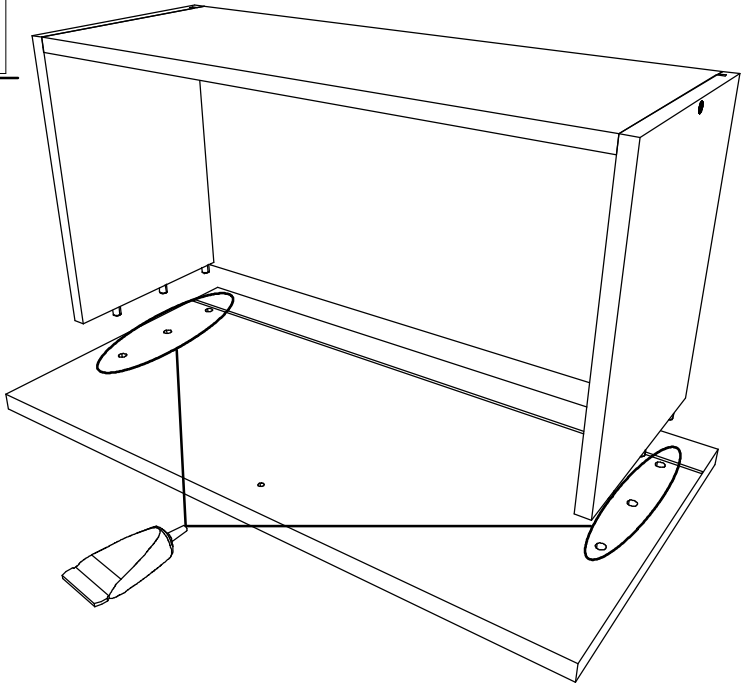
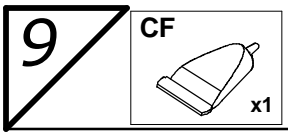

11

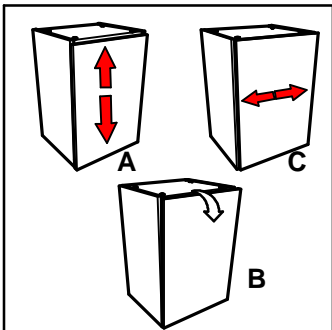
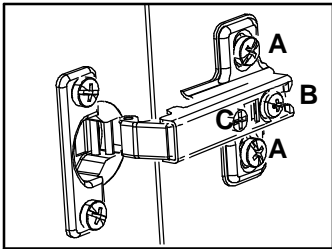
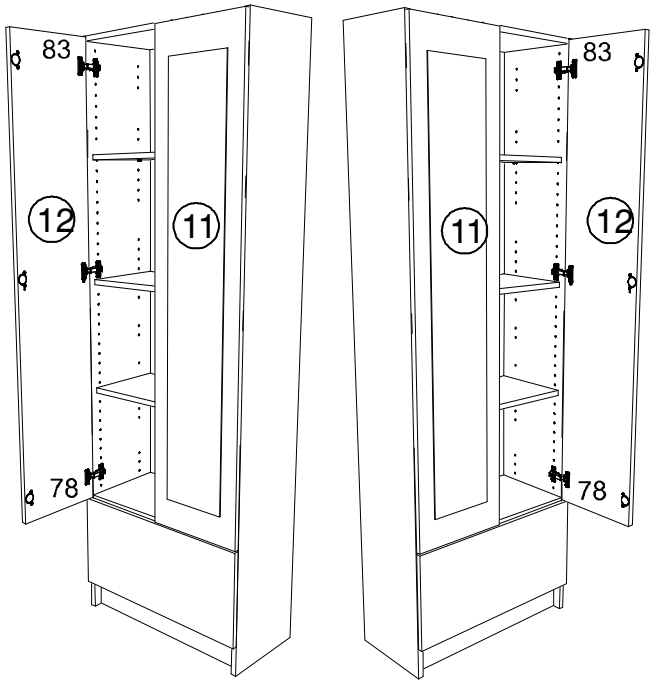
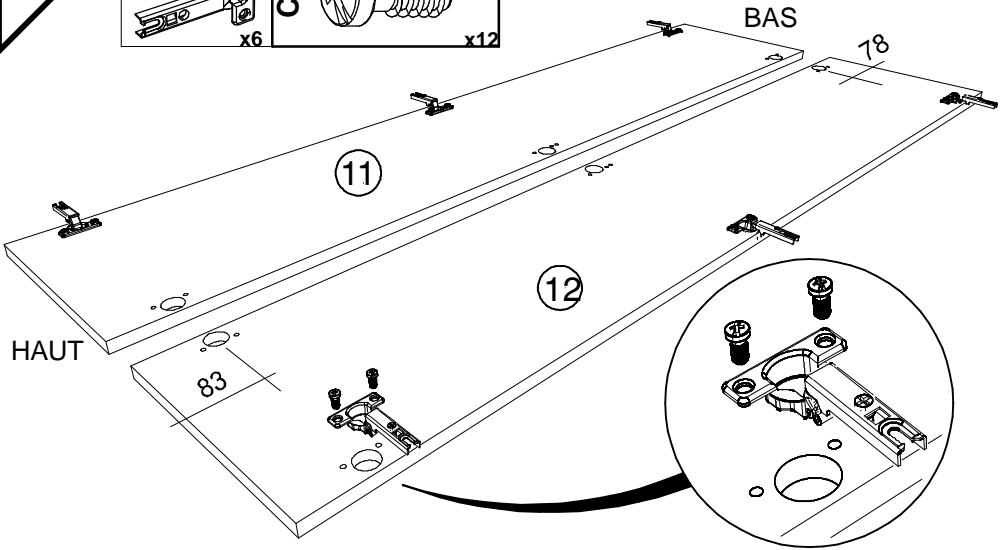
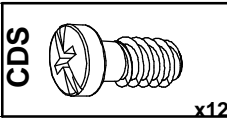
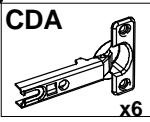

12

