

ASSEMBLY INSTRUCTION

MODEL : DTC 333-S5V - ELLA COMMODE 2 LADEN, 2 D/P / CHEST

HARDWARE	A	B	C	D	E	F	G	H	I	J	K	L	L1	L2	L3	M	N	N1	N2	O	P	Q	R
	1X41	1X24	1X16	1X4	1X8	1X16	1X7	1X6	1X8	13 SETS	1X2	1X4	1X4	1X4	4 SETS	2 SETS	2 SETS	2 SETS	1X8	1X70	1X5	1X1	

Part List

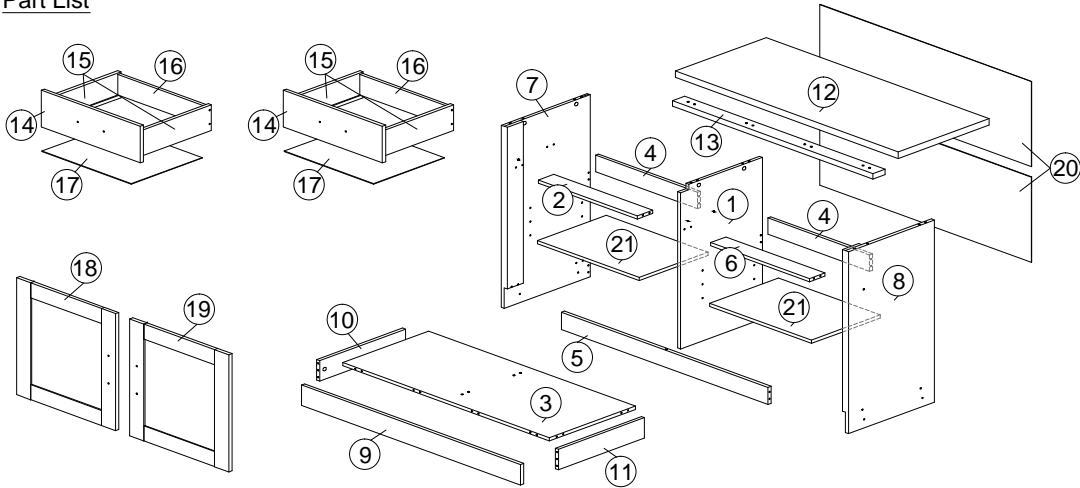

STEP 1

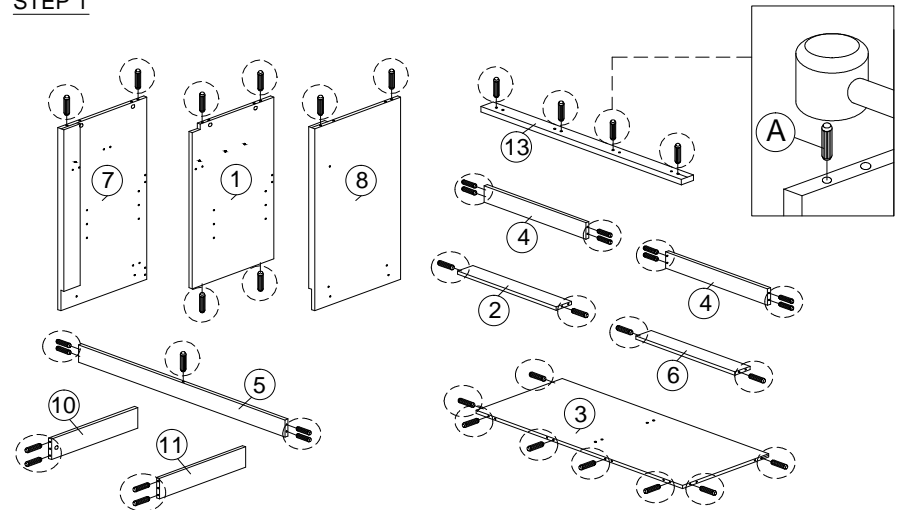

STEP 2

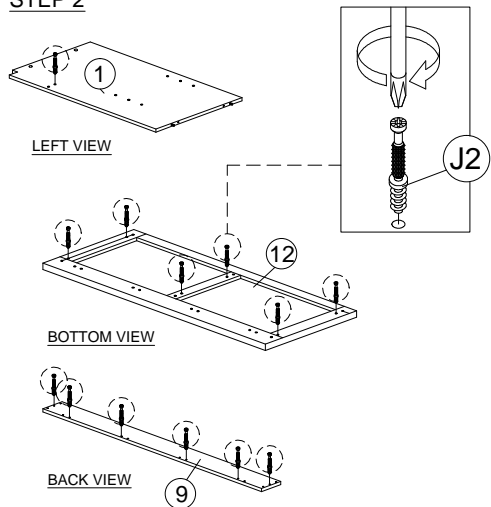

STEP 3

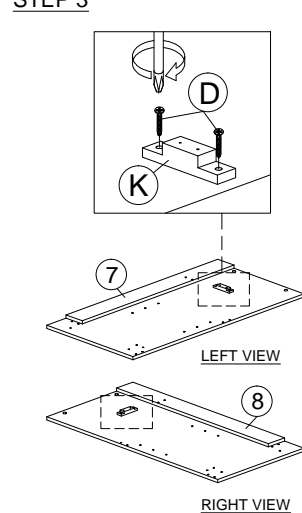

STEP 4

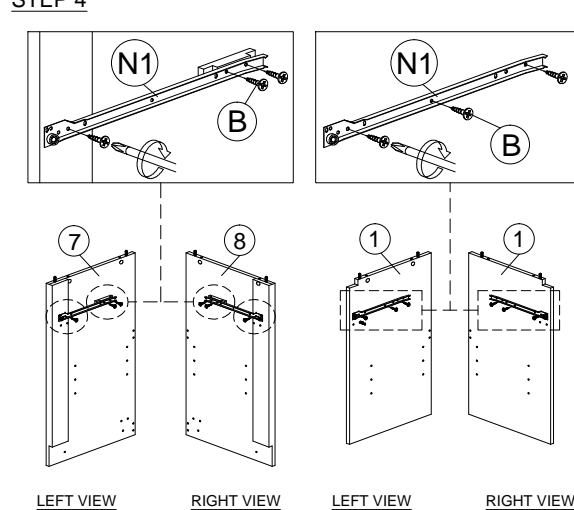

STEP 5

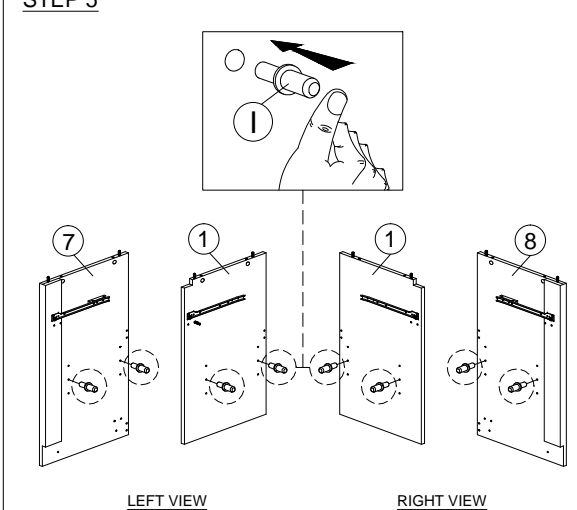



SOFT, DRY CLOTH

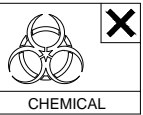

CHEMICAL

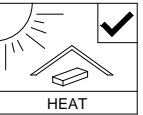

HEAT



KEEP DRY

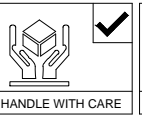

HANDLE WITH CARE



DO NOT USE KNIFE

ASSEMBLY INSTRUCTION

MODEL : DTC 333-S5V - ELLA COMMODE 2 LADEN, 2 D/P / CHEST

STEP 6

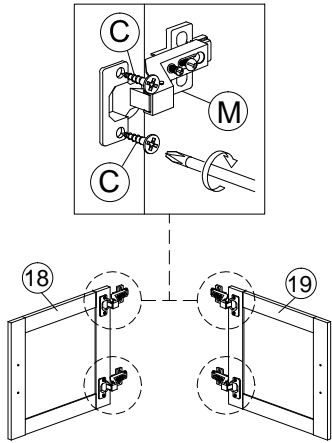

BACK VIEW

STEP 7

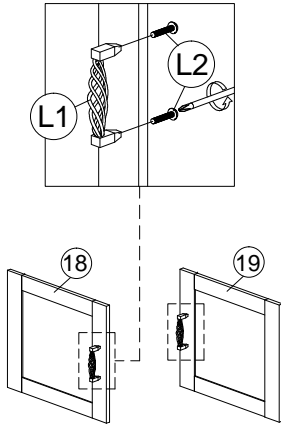

FRONT VIEW

STEP 8

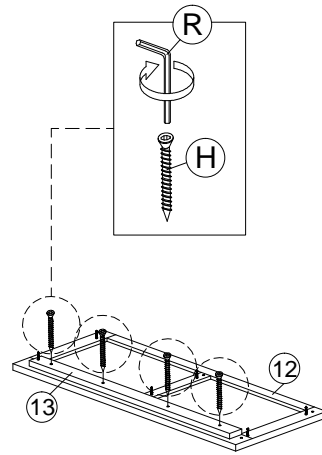

BOTTOM VIEW

STEP 9

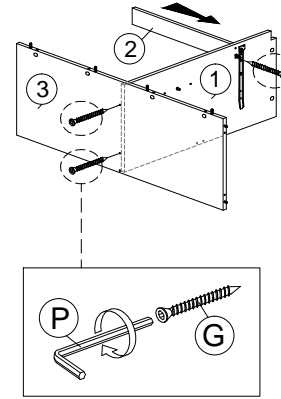

STEP 10

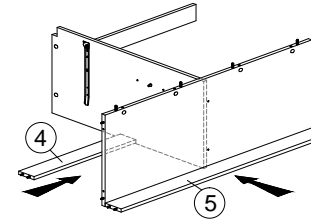

STEP 11

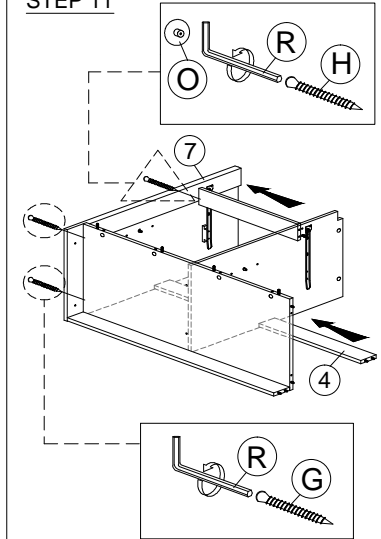

STEP 12

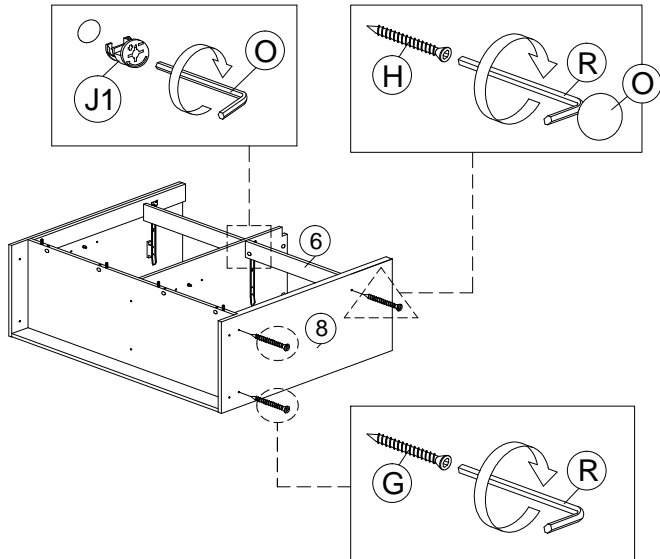

STEP 13

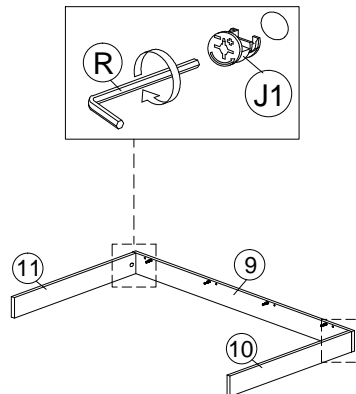

STEP 14

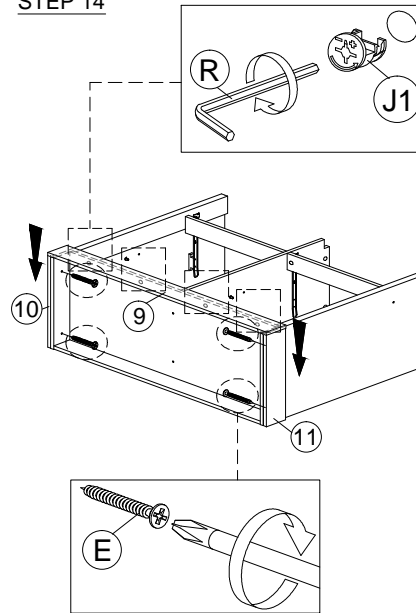

STEP 15

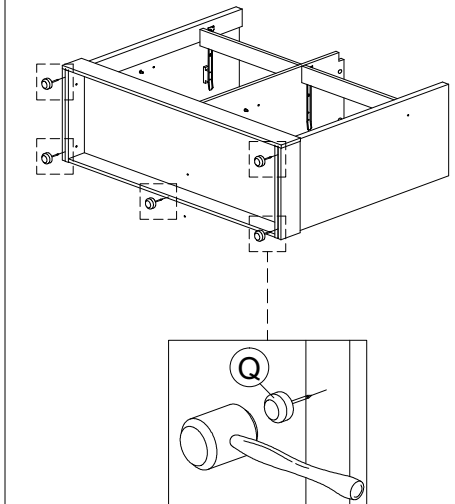

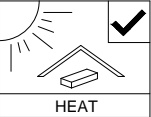
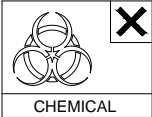

ASSEMBLY INSTRUCTION

MODEL : DTC 333-S5V - ELLA COMMODE 2 LADEN, 2 D/P / CHEST

STEP 16

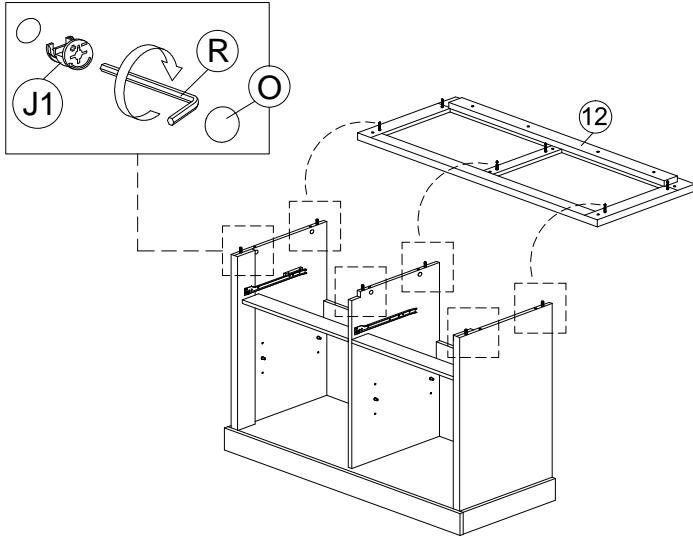

STEP 17

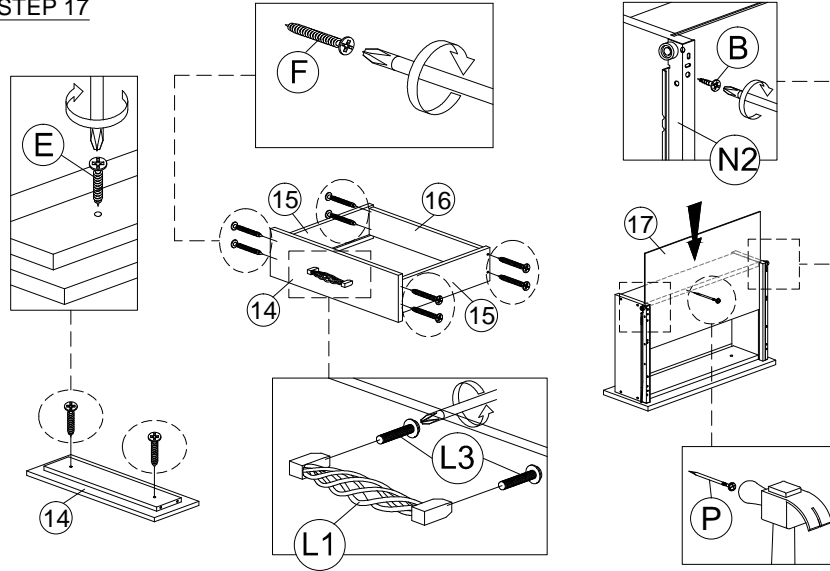

STEP 18

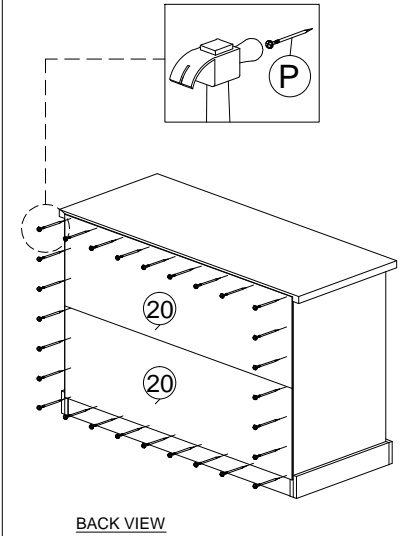

STEP 19

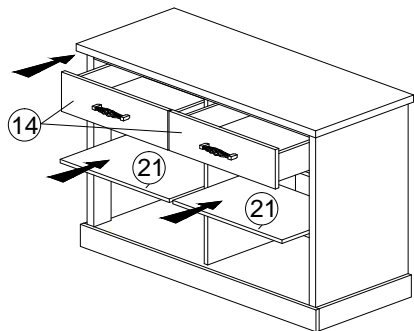

STEP 20

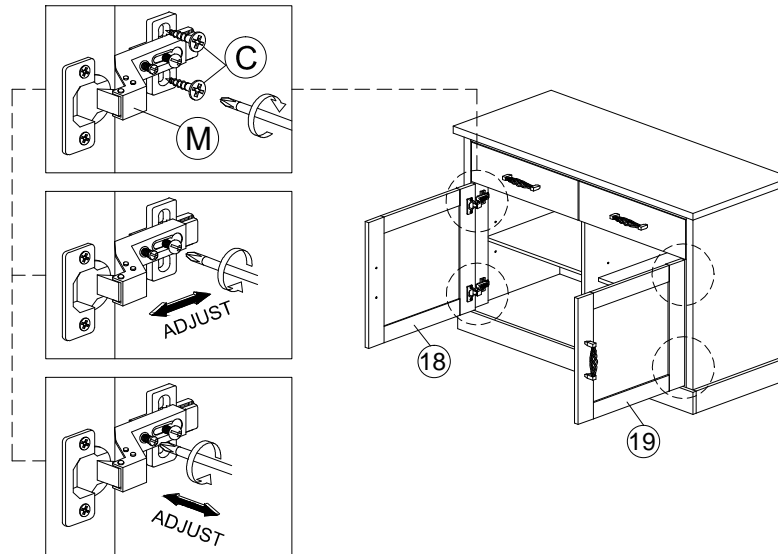

COMPLETED

